

Features: ~

- Display: 24mm LCD display with backlight
- Gross Weight: 2.5kg
- 24mm LCD display with backlight
- Rechargeable battery operation, up to 90 hours of continuous use
- Programmable

Function include units conversion, counting, check weighing, accumulation, animal scale
(Optional) RS232 interface with LP-50 label printer, TPuP mini printer or computer connectivity

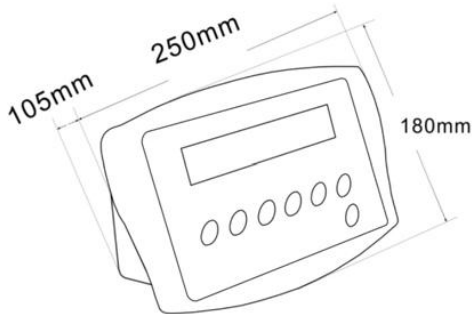

Specification: ~

Model	TKW-Series			
Capacity	1 ton	3 tons	5 tons	10 tons
Platform size	1m x 1m	1.2m x 1.2m	1.5m x 1.5m	

* Designs and specifications are subject to change for improvement without prior notice.

BAN HING HOLDING SDN BHD

No. 13-3, Jalan Raja Laut, 50350 Kuala Lumpur, Malaysia.

Tel: 603-4048 1000 / 4042 5970

Fax: 603-4050 8000

Website: www.banhing.com

Email: enquiry@banhing.com